



PORTA

SOLAR MOLIBE PORTABLE POLE
Installation Manual

Ideal for Construction, Natural Disasters,
and Other Temporary Lighting Needs.

PORTA

SOLAR MOLIBE
PORTABLE POLE

72lbs



150lbs



Contents

01 Introduction	04
02 Specifications	06
03 Installation and Wiring Requirements	09
04 Ordering Information	09
05 Installation	010
06 Panel Angle	012
07 Remote Control Guide	014

01 Introduction

Thank you for purchasing the PORTA solar molibe portable pole.

Introduction

Outdoor solar lighting systems use solar cells which convert sunlight into electricity. Electricity is stored in batteries for use at night. PROTA solar molibe portable pole combined with SOLTECH solar lights are easy to install and virtually maintenance free. Using them avoids trenching, cabling, and electricity costs .

Important

In order to avoid deep discharge of the battery during storage, please fully recharge your battery every 4 months. Please make sure that the light is installed in an area with sufficient sunlight. A strict minimum of 3.5 hours/day of sunshine on average is recommended. Select the right operating mode according to local codes and solar conditions. Keep it away from shadows. Self-cleaning occurs when the light fixture has minimum angle of 15 degrees above horizontal.

Please save these instructions. Read all of the instructions carefully before attempting to carry out any installation or wiring. Do not open or attempt to repair a SOLTECH luminaire on your own, as it may cause serious damage and would void the product warranty. Contact your local distributor for any questions concerning the installation.

Precautions when working with solar panels

When the solar panel is exposed to sunlight, a voltage appears at the output terminals of the solar panel, turning it into a source of electricity. To avoid a shock hazard, make sure the solar panel is covered with an opaque (dark) covering, such as paper or cloth, during the installation. Do not make contact with the terminals when the panel is exposed to sunlight or any other light source.

Luminaire Options

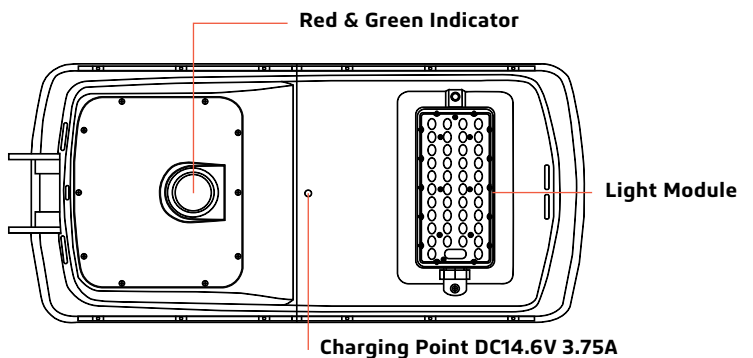
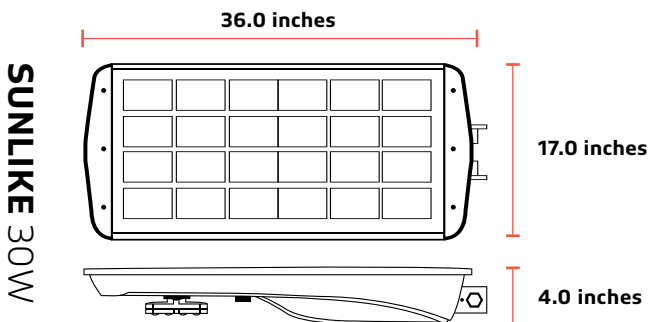
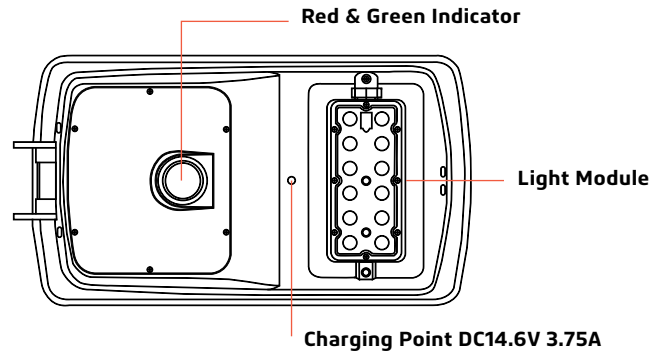
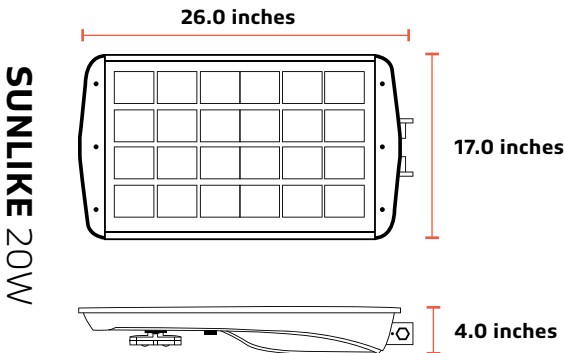
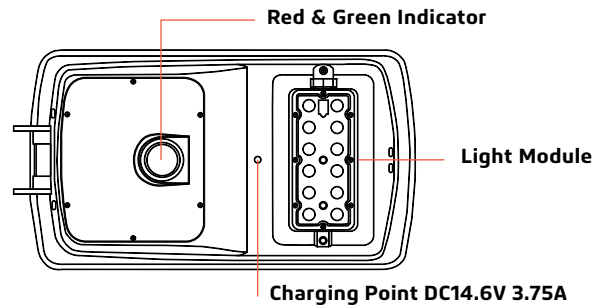
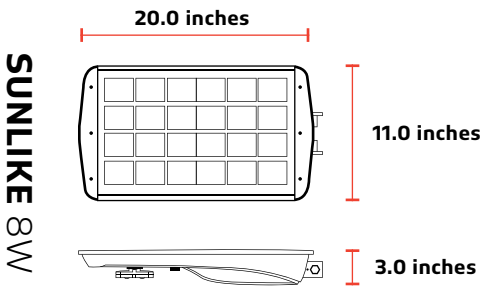

FLUX 20W

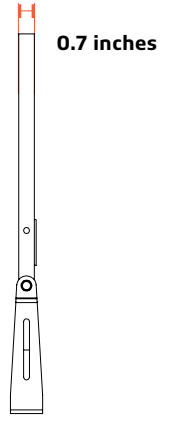
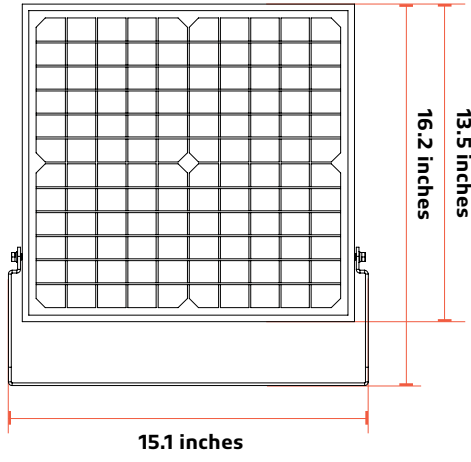
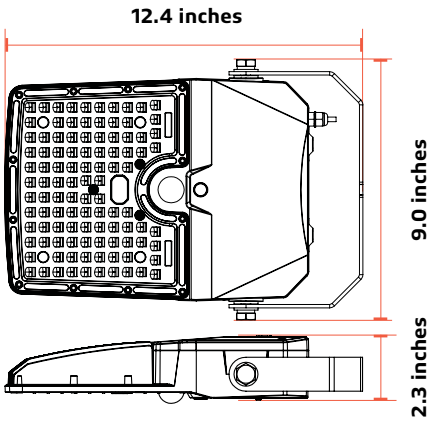

FLUX 6W

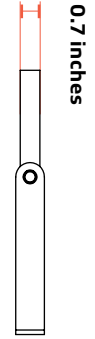
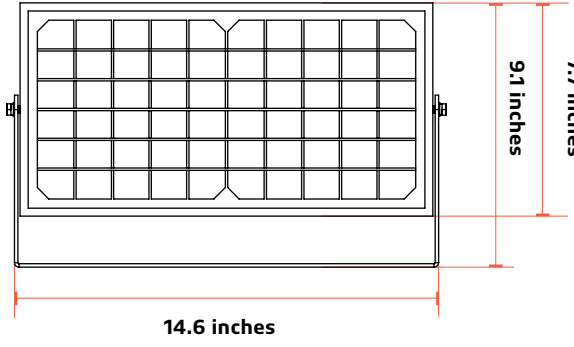
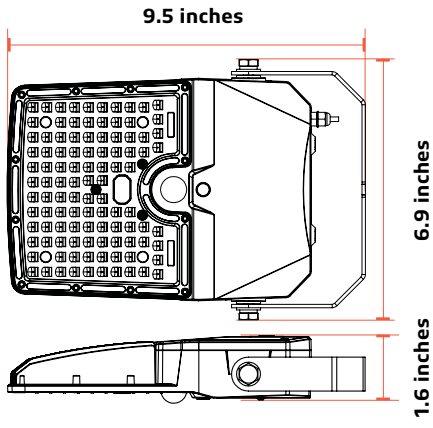

02 Specifications

Specifications	PORTA	
Pole Height Options	5ft / 8ft (Without Luminaire)	
Base Weight Options	72lbs / 150lbs	
Casting	Aluminum and Rubber	
Base Dimensions	72lbs: 18 X 18 X 14 In	150lbs: 23 X 23 X 18 In
Pole Profile	Round	
Pole Sections	1	

BASE SIZE

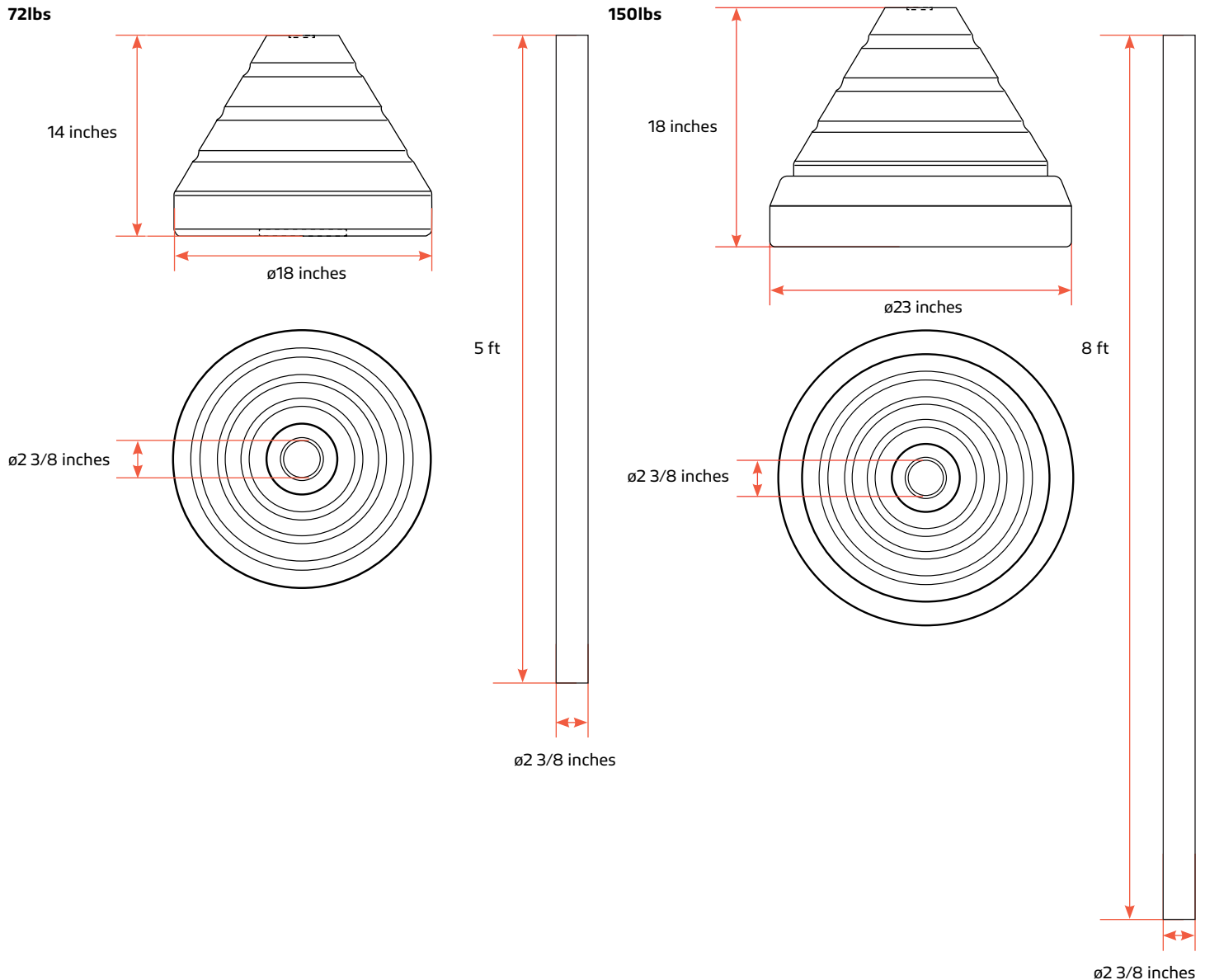

Specifications	FLUX 6W	FLUX 20W
LED Nominal Power	6W	20W
Solar Panel	Mono-Crystalline 10V 10W	Mono-Crystalline 10V 20W
LiFePO ₄ Battery	6.4V 3AH	6.4V 12AH
CCT	4,000K	4,000K
Lumen Output@4000K	1,020	3,400
CRI	> 70	> 70
Product Size	Light Head 9.5 X 6.9 X 1.6 Inches Solar Panel 7.7 X 14.6 X 0.7 Inches	Light Head 12.4 X 9.0 X 2.3 Inches Solar Panel 13.5 X 15.1 X 0.7 Inches
Beam Spread	>130°, NEMA type 7 Very Wide	>130°, NEMA type 7 Very Wide
EPA	1.41	2.51
Cable Length	16.5 ft	16.5 ft
IP Rating	IP66	IP66
Casting	PC & Aluminum	PC & Aluminum
Efficiency@4000K	170 lm/W	170 lm/W
* Charging Time	6hrs (1000W/m ²)	6hrs (1000W/m ²)
Run Time (@Full Charged)	5-7 Rainy Days	5-7 Rainy Days
Operation Mode	7 Operating Modes	7 Operating Modes
PIR Sensor Angle / Distance	360° / 16.4 ft	360° / 16.4 ft
* Operating Temperature	0°C/32°F to 140°F	0°C/32°F to 140°F
* Charging Temperature	0°C/32°F to 140°F	0°C/32°F to 149°F

* The temperature can impact the battery's charging and normal operation. If your place's temperature is under 32°F, we advice you to use the SUNLIKE PRO version to achieve better lighting results.

* The solar charge time data is base on 77 degree F ambient temperature with the panel pointed directly at the solar radiation. The standard radiation value is 1000W/m².

02 Specifications

Specification	SUNLIKE 8W	SUNLIKE 20W	SUNLIKE 30W
LED Nominal Power	8W	20W	30W
Solar Panel	18V 17W	18V 36W	18V 52W
LiFePO ₄ Battery	115.2WH 12.8V 9AH	256WH 12.8V 20AH	384WH 12.8V 30AH
Weight	11.7 lbs	21.4 lbs	29.8 lbs
Lumen Output@5000K	1,600	4,000	6,000
CRI	> 70	> 70	> 70
LED Chip	Lumileds 5050 (215lm-CR>70)	Lumileds 5050 (215lm-CR>70)	Lumileds 5050 (215lm-CR>70)
EPA@45°	1.7	2.7	3.7
Waterproof Rate	IP65	IP65	IP65
Casting	Aluminum	Aluminum	Aluminum
Efficiency@5000K	200 lm/W	200 lm/W	200 lm/W
* Charging Time	7hrs	7hrs	7hrs
Run Time(@Full Power)	10hrs	10hrs	10hrs
Operation Mode	Remote control and One-key Setting	Remote control and One-key Setting	Remote control and One-key Setting
* Operating Temperature	-20°C/-4°F to 140°F	-20°C/-4°F to 140°F	-20°C/-4°F to 140°F
* Charging Temperature	0°C/32°F to 140°F	0°C/32°F to 140°F	0°C/32°F to 140°F
Maximum Autonomy			
Motion Sensor Mode	40%-100% 35hrs 20%-80% 55hrs	40%-100% 35hrs 20%-80% 55hrs	40%-100% 35hrs 20%-80% 55hrs
Time Control Mode	Night Owl 28hrs Early Bird 25hrs	Night Owl 28hrs Early Bird 25hrs	Night Owl 28hrs Early Bird 25hrs
Constant Mode	100% 12hrs 70% 17hrs 40% 30hrs	100% 11hrs 70% 15.5hrs 40% 27hrs	100% 11hrs 70% 15.5hrs 40% 27hrs

* The temperature can impact the battery's charging and normal operation. If your place's temperature is under 32°F, we advice you to use the SUNLIKE PRO version to achieve better lighting results.

* The solar charge time data is base on 77 degree F ambient temperature with the panel pointed directly at the solar radiation. The standard radiation value is 1000W/m².

03 Installation and Wiring Requirements

1. Installation and wiring must comply with the State and National Electrical Codes.
2. The SUNLIKE, FLUX, BEACON and SOLPAD models are intended for outdoor use only and should not be installed in an unventilated area, and must be installed in an environment within the operating temperatures defined for the product.
3. The average sunshine in the installation area should be above 3.5 hours/day in order to ensure full function of the light fixture. Avoid areas with shade.
4. Before installation, if applicable, please ensure the light pole and its foundation are stable enough to withstand the lighting fixture(s).
5. Before installation, please ensure that the battery is fully charged. Install during sunny days if possible.
6. Before installation, press the  ON/OFF key on the remote control (if it has) and check whether it shows a red light on the indicator. Cover the solar panel and check if the light module turns on normally within 1 minute.

After Installation

The light fixture will automatically turn on at night and turn off during daylight.

Important

Always orient the solar panel facing the equator (e.g. facing south if in northern hemisphere).

Always have a tilt angle of at least 15° to avoid dust accumulation (0°=horizontal plane).

04 Ordering Information

Base	Pole	Fixture
STLPORBA72=PORTA 72lbs Rubber Base	STLPORPL5=PORTA 5ft Aluminum Pole	STLSTC08T35SFGY=SUNLIKE 8W
STLPORBA150=PORTA 150lbs Rubber Base	STLPORPL8=PORTA 8ft Aluminum Pole	STLSTC20T35SFGY=SUNLIKE 20W
		STLSTC30T35SFGY=SUNLIKE 30W
		STLFLX63PMBZ=FLUX 6W
		STLFLX204PMBZ=FLUX 20W

For example: **STLPORBA72STLPORPL5STLSTC30T35SFGY**

This means the customer wants a Solar Mobile Portable Pole PORTA with 72lbs Rubber Base, 5ft Pole Height and SUNLIKE 30W Fixture.

DO NOT send the sample number directly to our salesperson. Use the information in the chart above to create a model number with the correct series, wattage, temperature, mounting option, and finish for the product that you want.

05 Installation

PORTA POLE INSTALLATION

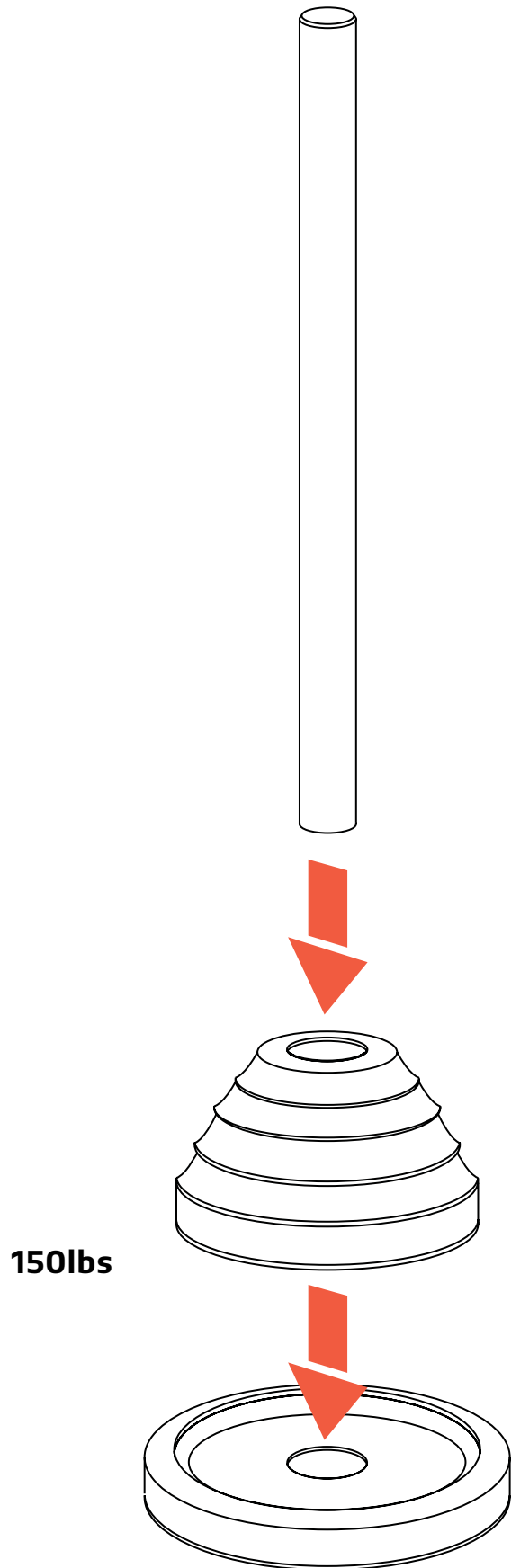
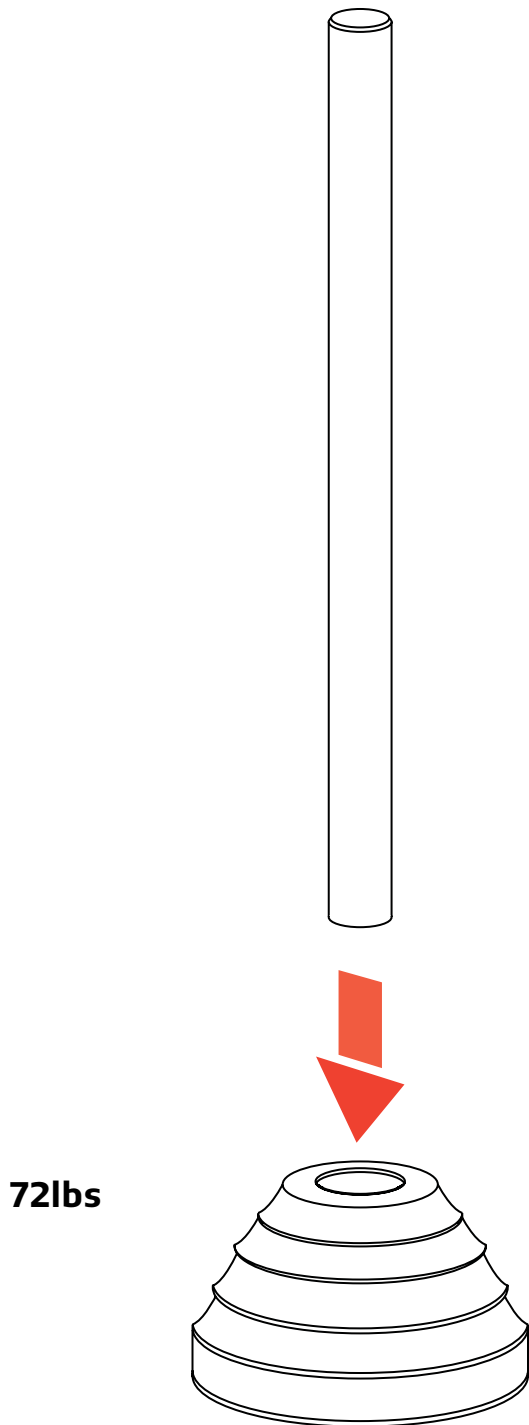

SUNLIKE 8W / 20W / 30W INSTALLATION

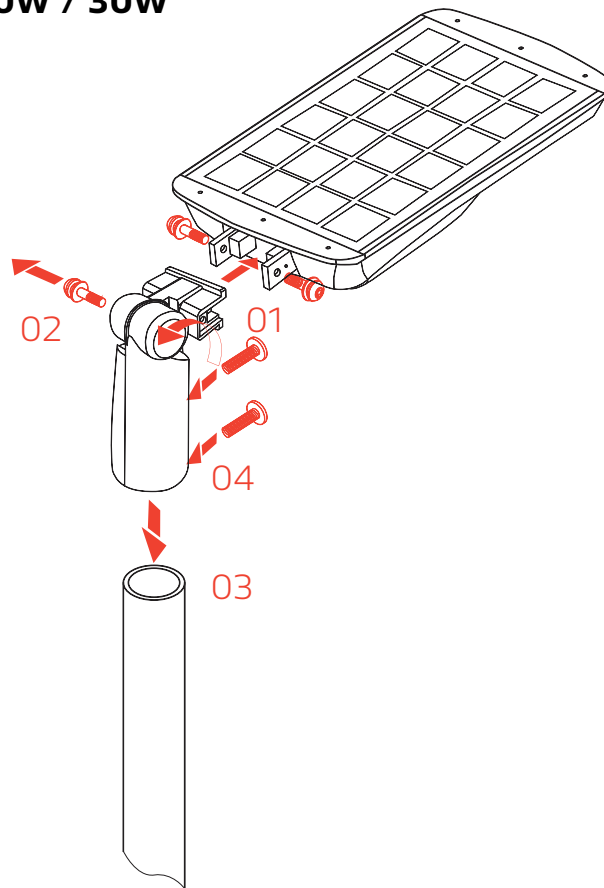

1. Connect SUNLIKE fixture with slip fitter.
2. Adjust the panel angle.
3. Mount slip fitter on the top of the PORTA pole.
4. Tighten up two screws to screw the SUNLIKE fixture.

FLUX 6W / 20W INSTALLATION

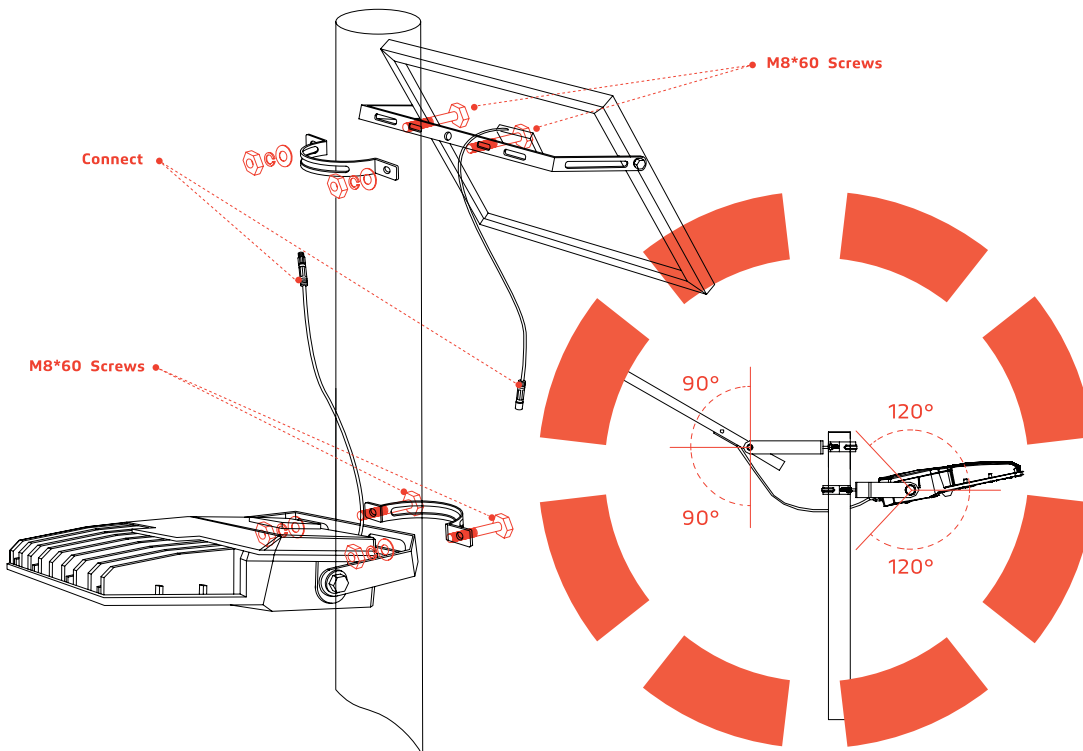

First, mount the solar panel to the pole:

1. Use the screw kit to secure the pole mount base and the solar panel bracket to the pole.
2. Then attach the solar panel to the bracket.

Then, mount the fixture:

3. Attach the bracket to the fixture.
4. Use the screw kit to secure the fixture bracket to the pole mount base on the pole.
5. Connect the light and solar panel cables.

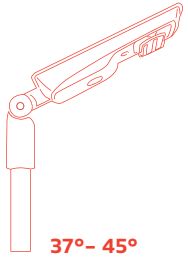

Alaska

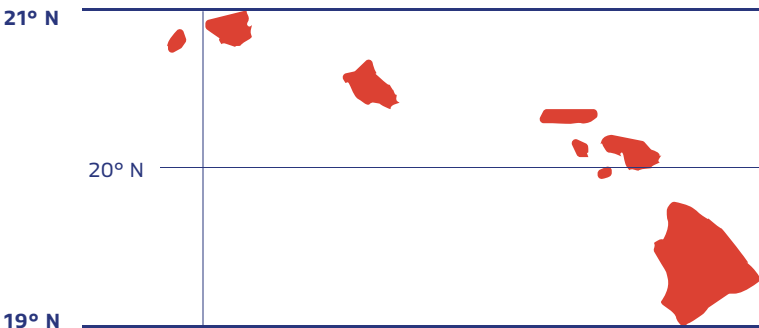
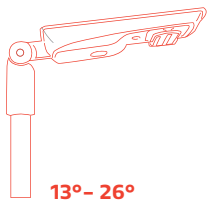
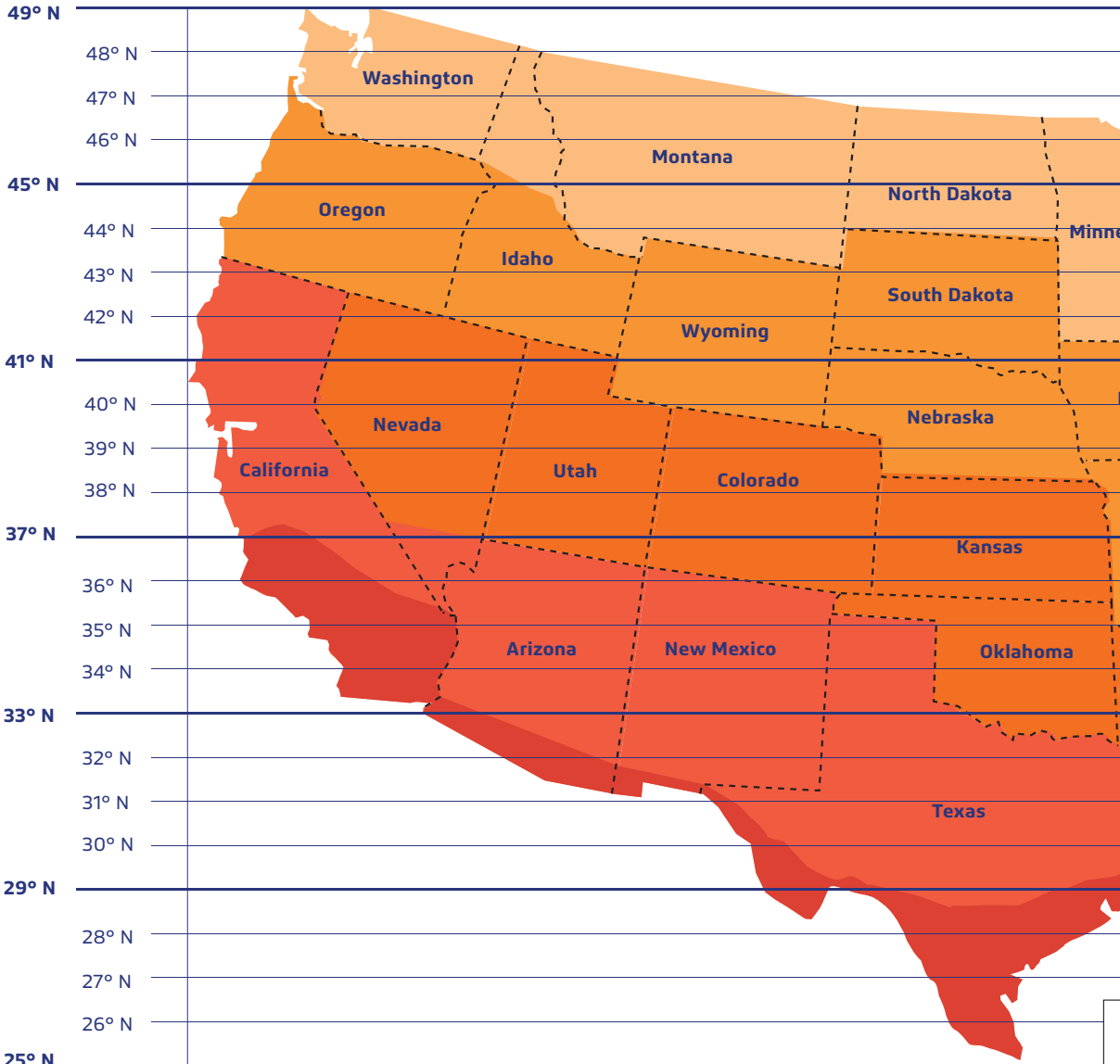
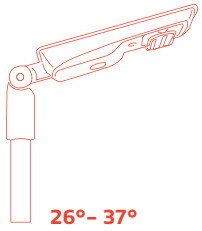

Hawaii

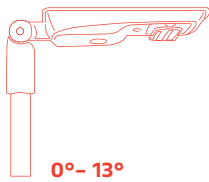

06 Panel Angle

The Solar charge in a battery pack won't last forever. The off-grid system relies on stored solar energy for autonomy. Angling your solar panels properly can boost the power intake of your solar lighting system. You want to angle your solar panels at a tilt based on the area's latitude.

Tip

You can increase the tilt 15° in the winter or decrease 15° in the summer. In this way you can get the maximum sunlight to recharge the battery bank.

Key



Best Facing Direction of Solar Panel

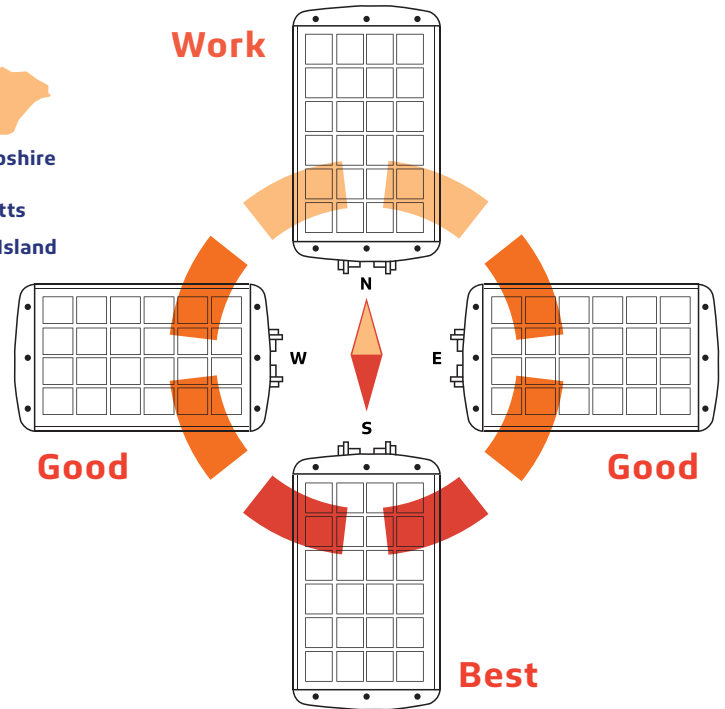

The area will dictate the installation of the fixtures and will sometimes prevent the lights from facing south. But that's okay! Panels facing West & East won't get as much light as Southern facing panels, but will still collect a good amount of sunlight. A North facing panel also works, but it will take longer to charge than any other direction. This would mean that the solar charge will be less optimal if installations are facing North.



World Wide Panel Angles

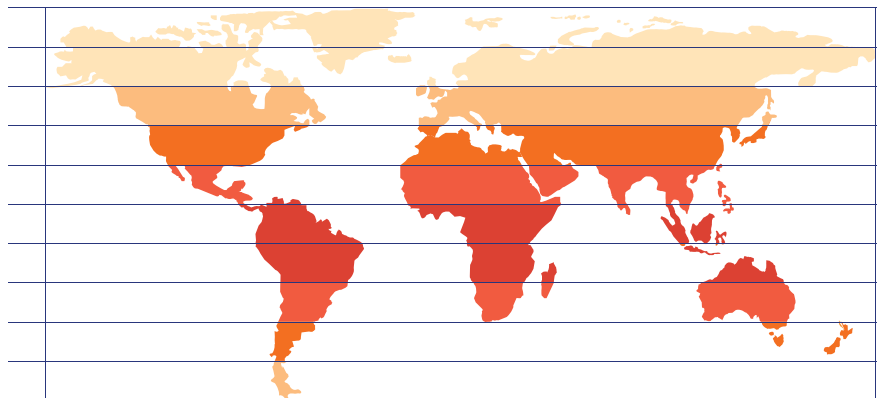
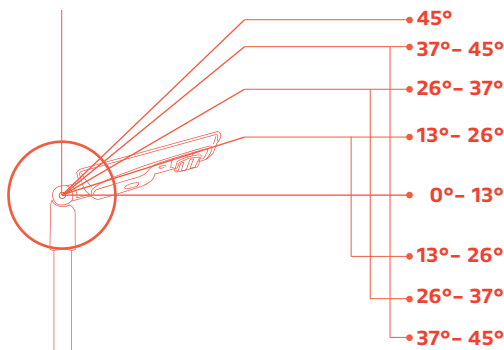

07 Remote Control Guide

This guide is for **SUNLIKE** Fixture only.

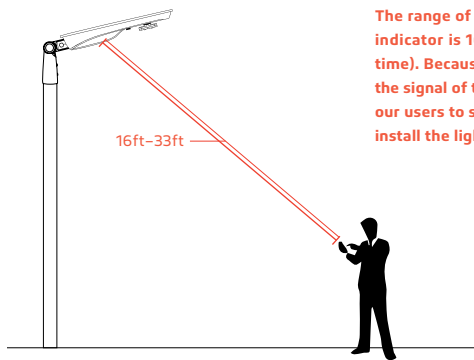

The range of the remote control to the indicator is 16ft (Day time) to 33ft (Night time). Because the sunlight will impact the signal of the remote control, we suggest our users to setup the mode before they install the light.

1. On/Off

When off is selected, the light will stop working. The solar panel will not charge the battery and the battery will not supply electricity to the light.

2. Connect/Test

Remote control device can be connected with any lighting fixture, one at a time. To connect, press the button once. It also functions as a test button. To test, press the "Test" button once, the red light will indicate the fixture is charging, green light indicates that the fixture is operating. Testing lasts for 10 seconds, and then it goes back to the mode previously in use.

3. 40%-100% Motion Sensor Mode

Constant 40% brightness (turns on at dusk, turns off at dawn); 100% brightness turns on for 2 minutes when motion is detected.

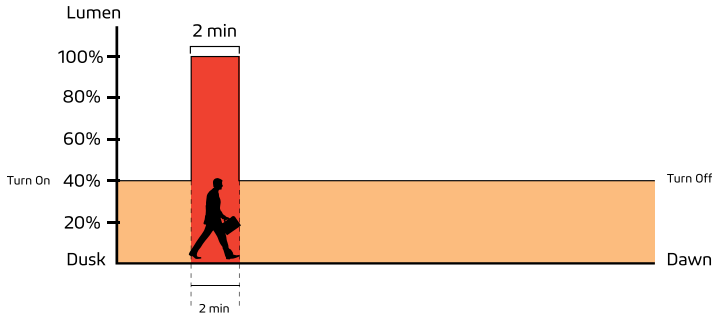

4. 20%-80% Motion Sensor Mode (Default)

Constant 20% brightness (turns on at dusk, turns off at dawn); 80% brightness turns on for 2 minutes when motion is detected.

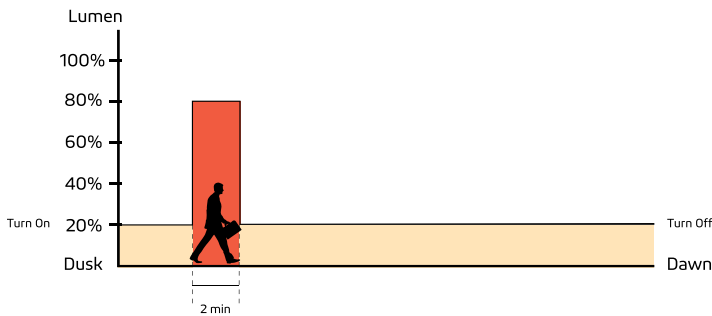

5. Night Owl Mode

Changes as natural light decreases/increases (turns on at dusk); 70% brightness for 0.5 hour, 100% brightness for 3.5 hours, 70% brightness for 1 hour, 50% brightness for 1 hour, 20% brightness for 5 hours (turns off at Dawn).

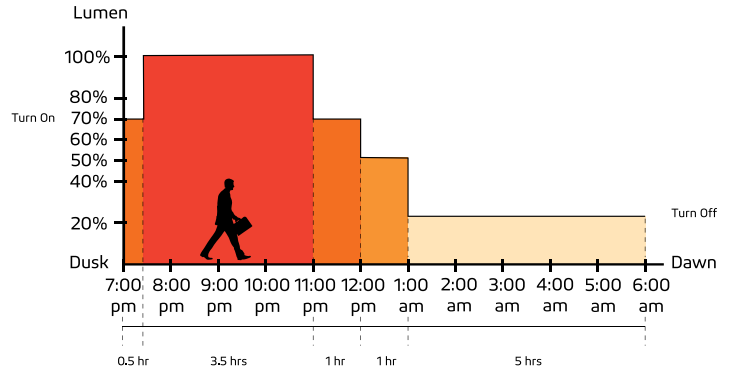

6. Early Bird Mode

Changes as natural light decreases/increases with increased brightness near dawn for early risers (turns on at dusk); 70% brightness for 0.5 hour, 100% brightness for 3.5 hours, 70% brightness for 1 hour, 50% brightness for 1 hour, 20% brightness for 4 hours, 100% brightness for 1 hour (turns off at Dawn).

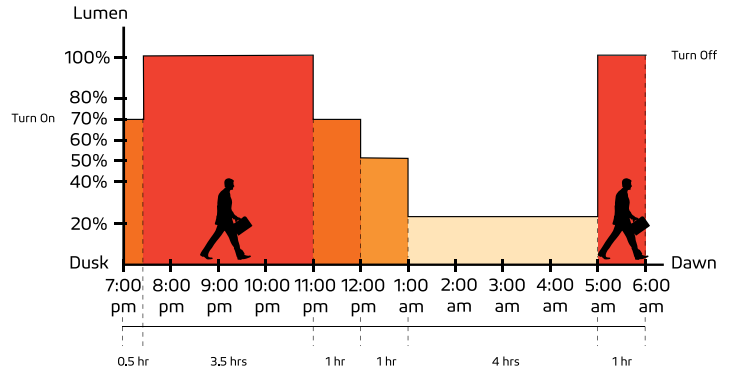

(IAP) Intelligent Adaptive Program Battery Control Technology

In order to extend the off-grid autonomy of the SOLTECH solar products under shady trees, heavy rain, and thick clouds, our controllers now integrate an adaptive smart control feature to actively track battery capacity and adjust light output accordingly. Before integrating this feature, selecting a light output percentage on the remote would yield an accurate percentage of max LED brightness. Now with (IAP), the controller actively monitors the battery and regulates the electrical current to the LEDs. The controller makes light output of the selected percentage on the remote relative to battery capacity rather than max LED output. This smart-control feature can increase our off-grid performance by up to 40%.

Important

Dust and dawn time can vary for different locations and seasons. The sensors in our products will monitor the light levels where it is installed. The time period shown in the chart above is just an example to help you understand the different lighting modes.

07 Remote Control Guide

7. 100% Constant Mode

100% brightness from dusk to dawn.

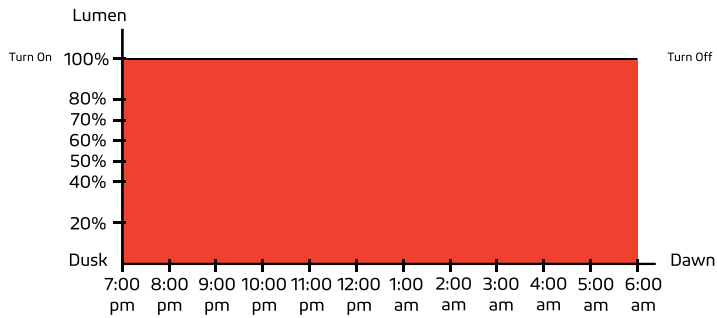

8. 70% Constant Mode

70% brightness from dusk to dawn.

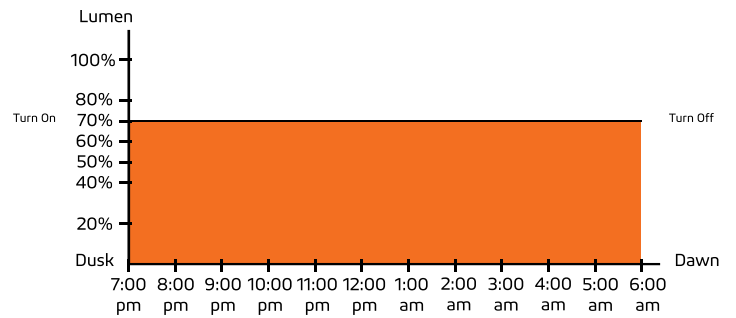

9. 40% Constant Mode

40% brightness from dusk to dawn.

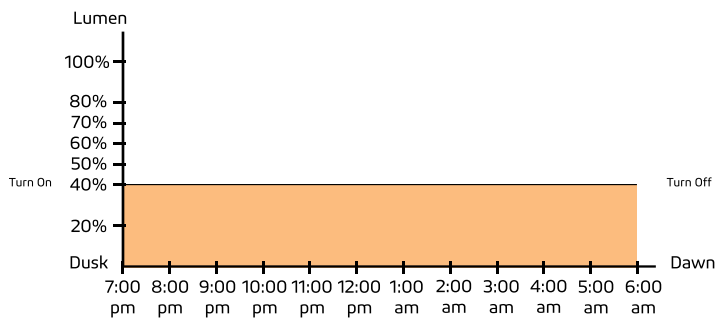

10. Timer Mode Disabled

Press this button to turn off Timer Mode; settings revert back to before Timer Mode was last activated.

11. Timer Mode 4 Hours

This is an additional mode which can work with any other modes. For example: press this button at any time after you turn on 70% Constant Mode. If the light turns on at 7pm at dusk, it will turn off at 11pm. It will repeat the same schedule hereafter until it is canceled by pressing Timer Mode Disabled.

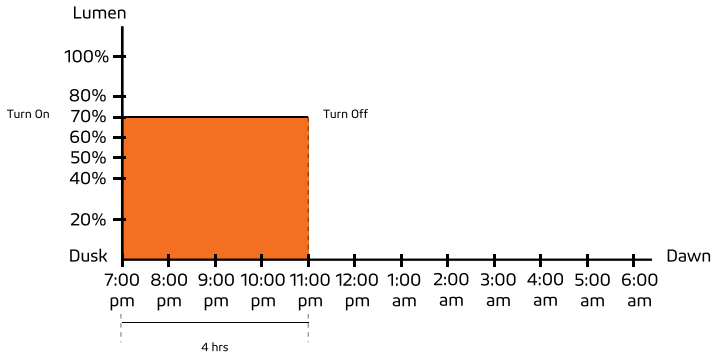

12. Time Mode 8 Hours

This is an additional mode which can work with any other modes. For example: press this button at any time after you turn on 70% Constant Mode. If the light turns on at 7pm at dusk, it will turn off at 3am. It will repeat the same schedule hereafter until it is canceled by pressing Timer Mode Disabled.

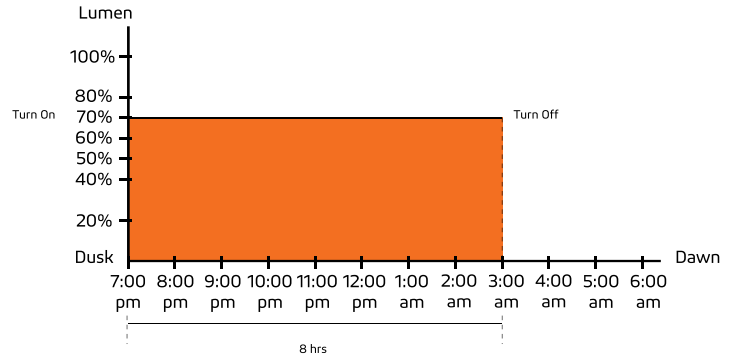

Important

Dust and dawn time can vary for different locations and seasons. The sensors in our products will monitor the light levels where it is installed. The time period shown in the chart above is just an example to help you understand the different lighting modes.

PORTA Solar Mobile Pole products are covered by a 3 years limited warranty. SUPER EMPOWER warrants to the original purchaser that this product is free from defects in materials and workmanship for the period of 3 years from date of purchase. To obtain warranty service please contact your local distributor or sales rep for further instruction.



1460 Park Avenue.
Emeryville, CA 94608 USA

www.super-empower.com

SOLTECH LLC reserves the right to update all product data sheets at any time. Consult SOLTECH marketing specialists for publication updates at hello@soltechlighting.com

*Copyright©2018–2025 SOLTECH LLC,
All Rights Reserved.*



"WE EMPOWER WATT MATTERS"