

**Lithium-Ion Battery**  
12.8V 600Ah  
7,680WH

# INSTALLATION AND OPERATION GUIDE

## **APPLICATIONS**

- Outdoor Recreation
- AGM Batteries Replacement
- Power Backup

[www.super-empower.com](http://www.super-empower.com)

# —PACKING LIST

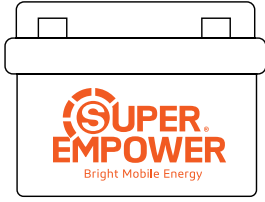

**Battery x 1**

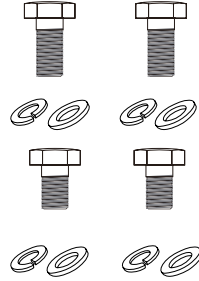

**Screw x 4**

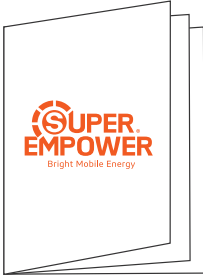

**Specification x 1**

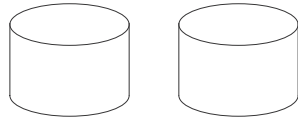

**Plastic Insulation Cap x 2**

## THANK YOU!

*Dear Valued Customer,*

*Thank you for choosing SUPER EMPOWER® batteries. We greatly appreciate your support. Our team works diligently behind the scenes to create advanced battery systems and provide top-notch service to our customers. Support and feedback from our customers along with the hard work and dedication of our staff allow us to deliver exceptional products, competitive prices, and an overall excellent experience.*

*Thanks again for giving us your vote of confidence. We hope that you'll enjoy using our products as much as we've enjoyed creating them. Please feel free to reach out to us if you have any questions.*

# —CAUTION

## Disclaimer

The manufacturer accepts no liability for any damage caused by: Force majeure includes fire, typhoon, flood, earthquake, war, and terrorism.

Intentional or accidental misuse, abuse, neglect or improper maintenance, and use under abnormal conditions.

Improper installation, improper operation, and malfunction of a peripheral device.

Contamination with hazardous substances, diseases, vermin, or radiation.

Alterations to the product without express written consent from the manufacturer.

# —IMPORTANT SAFETY INSTRUCTION

- **Please keep the battery away from heat sources, sparks, flames, and hazardous chemicals.**

- **Maintain Adequate Ventilation and Heat Dissipation**

Place the battery in a well-ventilated area with sufficient heat dissipation to prevent overheating and damage.

- **Size the Battery Cables and Connectors Appropriately**

Use high-stranded copper connectors and heavy gauge cables to handle possible battery loads. Make sure to keep identical cable lengths. Avoid accidents caused by unsuitable connectors or cables that make the connection a heat source during battery operation.

- **Please tighten all cable connections, as loose cable connections can cause terminal meltdown or fire.**

- **DO NOT puncture, drop, crush, burn, penetrate, shake, or strike the battery.**

The battery should be securely fastened during handling to prevent impact or dropping. It should be safely secured to a solid plane and the cables safely tied to a suitable location to avoid arcing and sparking due to friction.

- **DO NOT press it by placing heavy stuff on top of it for long periods, which may damage it due to an internal short circuit.**
- **DO NOT immerse the battery in water whether the battery is in use or on standby.**
- **DO NOT open, dismantle, or modify the battery.**
- **DO NOT touch the exposed electrolyte or powder if the battery casing is damaged.**
- **Uncovered electrolyte or powder that has contacted the skin or eyes MUST be flushed out with plenty of clean water immediately. Seek medical attention afterward.**
- **Avoid Short Circuit**

Please use circuit breakers, fuses, or disconnects that have been properly sized by certified electricians licensed installers or regional code authorities to protect all the electrical equipment in your system. The battery has a built-in battery management system (BMS) that protects the battery cells from over-charge, over-discharge, and over-current, however this alone will not protect your system from severe electrical conditions.

- **Trained and certified technicians are required for safe and reliable installation. This product manual can only serve as a guideline as it cannot cover all possible scenarios**
- **Verify Correct Polarity**  
Please verify the polarity before connecting the wiring. Reverse polarity can and will destroy the battery and other electrical equipment. Use a multimeter to determine proper polarity.
- **Avoid Exposed Metal Terminals or Connectors**  
The terminals of this battery are always live. Avoid exposed metal terminals or connectors; DO NOT place tools on the terminals or touch them with bare hands; DO NOT short circuit or use outside of specified electrical ratings.
- **DO NOT dispose of the battery as household waste. Please use recycling channels in accordance with local, state, and federal regulations.**

## —WARNING

- Batteries are potentially dangerous and proper precautions must be taken during operation and maintenance.
- Improper use of the battery can lead to battery failure or other potential damage.
- Improper configuration, installation, or use of related equipment in the battery system may damage the battery and other related equipment.
- Please wear proper personal protective equipment when working on the battery.
- Battery installation and maintenance must be performed by trained and certified technicians.
- Failure to follow the warnings above can result in potential damage.

**If you have any questions or need any help, please feel free to contact us at [hello@super-empower.com](mailto:hello@super-empower.com).**

# **— CONTENTS**

<b>PRODUCT OVERVIEW</b>	07
<b>CHARGE-DISCHARGE CURVE</b>	08
<b>PRODUCT SPECIFICATIONS</b>	09
<b>CHARGING</b>	11
<b>INSTALLATION GUIDE</b>	12
<b>BMS FUNCTION</b>	15
<b>APPLICATION EXAMPLES</b>	16
<b>FAQS</b>	17
<b>WARRANTY AND RETURNS</b>	18

# —PRODUCT OVERVIEW

## Key Features

- Lithium Ion Phosphate(LiFePO<sub>4</sub>)chemistry provides exceptional stability and consistent performance.
- Advanced Battery Management System (BMS) ensures product safety and long lifespan.
- Supports fast charging and discharging
- Constant voltage and full usable capacity at any state of charge.
- IP65 Rated (Dust and Water Resistant)
- Grade UL94 V-0 (Fireproof)

## External Features



# — CHARGE-DISCHARGE CURVE

Charge-discharge Curve @ 77°F/25°C

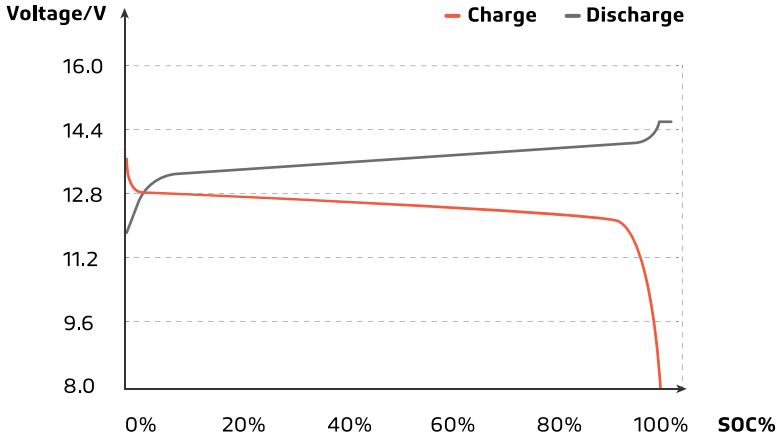

**Sample: 12.8V 600Ah battery**

\*Environmental conditions required for all tests: 77±9°F/25±5°C

## Connection Diagram

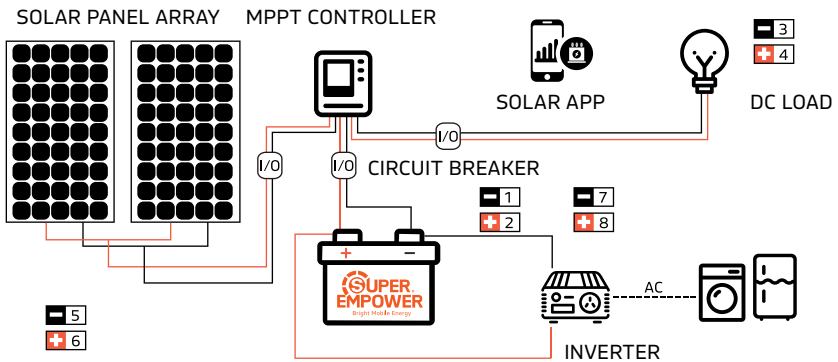

# — PRODUCT SPECIFICATIONS

## Battery Management System (BMS) Warning and Protection

Over-charge Voltage Protection	14.6±0.1V
Over-charge Voltage Protection Release	14.2±0.1V
Over-discharge Voltage Protection	9.2±0.12V
Over-discharge Voltage Protection Release	10.8±0.12V
Over-current Discharge Protection	200±10A
Over-current Charge Protection	210±10A
Short Circuit Current Protection	Support
Release Condition	Cut Load
Charging High Temperature Protection	140°F to 158°F
Discharge High Temperature Protection	149°F to 167°F
High Temperature Protection Release Condition	Drop by 41°F to 59°F
Charging Low Temperature Protection	23°F to 41°F
Discharge Low Temperature Protection	-13°F to 5°F
Low Temperature Protection Release Condition	Rise by 41°F to 59°F

# — PRODUCT SPECIFICATIONS

## Battery Parameters

Product	12.8V 600AH
Weight(lbs)	108
Dimensions(inch)	25.0x9.6x8.7
Terminal Bolt Size	M8
Rated Voltage	12.8V
Standard Charging Voltage	14.6V±0.2V
Shipping Voltage	12.8V to 13.5V
Shipping Capacity	50%
Cycle Life	6000@80% DoD
Self Discharge Rate	≤3%/Month
Series & Parallel connections	4 Parallel (Max) 4 Series (Max)
Communications	Not Supported
Case Material	ABS+PC/UL94-V0
Waterproof Grade	IP65
Battery Pack Certifications	CE/UN38.3/Class 9/IEC62133/ROHS
Cell Certifications	UL1642/UL2580/UN38.3
Storage Temperature	32°F to 140°F

# —CHARGING

## Charging with AC-DC Battery Charger

Check the AC-DC battery charger you intend to use has a dedicated lithium charge setting that meets the below charging requirements. A lot of battery chargers are designed for charging lead-acid batteries only and may not have a suitable charge setting for  $\text{LiFePO}_4$  battery.

### Charging Tips:

Use a 12.8V  $\text{LiFePO}_4$  battery charger

Recommended Charging Voltage:  $14.6\text{V} \pm 0.2\text{V}$

Recommended Charging Current:

Charging Current	Battery Model	12.8V 600AH
20A		30 Hrs
50A		12 Hrs

# —INSTALLATION GUIDE

## Installation Environment

The battery should be installed in a clean, cool, and dry place, away from water, oil, and dirt. The accumulation of these substances on the battery may cause leakage, resulting in self-discharge and possible short circuits. Adequate ventilation must be maintained to prevent the battery from overheating, and temperature fluctuations between the batteries should be minimized as much as possible.

## Preparation

Before installing and handling the battery, it is recommended that the following equipment or tools be available:

- Proper insulation protection equipment and tools
- Multimeter, battery cables
- Battery Charger/Charge Controller

## Inspection

Check for visible damage, including cracks, dents, deformations, and other visible anomalies. The top of the battery and terminal connections should be clean, dry and free of dirt and corrosion. If you find any problem with the battery, please contact us for assistance.

- 1. DO NOT short the battery terminals, as doing so may cause a current burst leading to irreversible damage to the system and battery.**
- 2. Please check the polarity before wiring. Polarity reversal will damage the battery.**
3. Protect all electrical equipment with circuit breakers, fuses, or appropriately sized circuit breakers as specified by a qualified electrician, licensed installer or regional regulatory authority.

## Cable Size

Cable size should be selected based on the expected load. Refer to the table below for the amperage of copper cables of different sizes.

Cable Specification and Capacity (AWG/MM <sup>2</sup> )	Current Capacity (A)
14(2.08)	20
12(3.31)	25
10(5.25)	35
8(8.26)	50
6(13.3)	65
4(21.1)	85
2(33.6)	115
1(42.4)	130
1/0(53.5)	150
2/0(67.4)	175
4/0(107)	230

## Best Practice Guidelines

### 1. Same brand

**(DO NOT connect any other brand, LiFePO<sub>4</sub> battery due to differences in the BMS)**

### 2. Same battery type(LiFePO<sub>4</sub>)

**(DO NOT connect any other battery type with this battery—such as li-ion, SLA etc.)**

**3. Same voltage,** it is recommended to use the battery fully charged (12.8V).

### 4. Same capacity

**5. The two batteries should be no more than 3 months older than each other.**

# —INSTALLATION GUIDE

## Connection Steps

**STEP 1.** Fully charge the battery separately

**STEP 2.** Wait 15 mins then test the voltage, it should be >13V

**STEP 3.** Connect your batteries in series or/and in parallel

(Taking a 12V 50Ah battery as an example)

### Series Connection

48V 50Ah

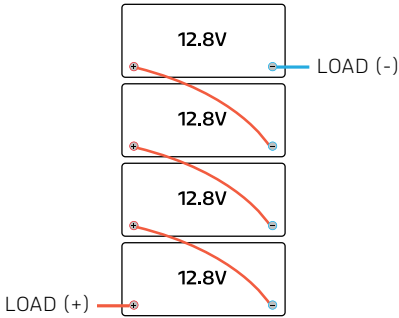

### Parallel Connection

12V 200Ah

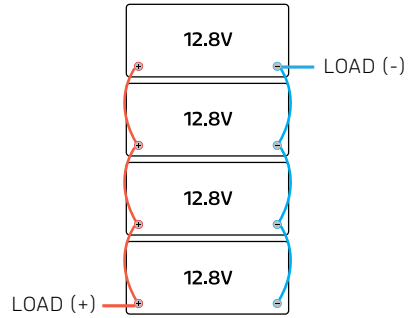

### Max. Connect in Series & Parallel (4S4P)

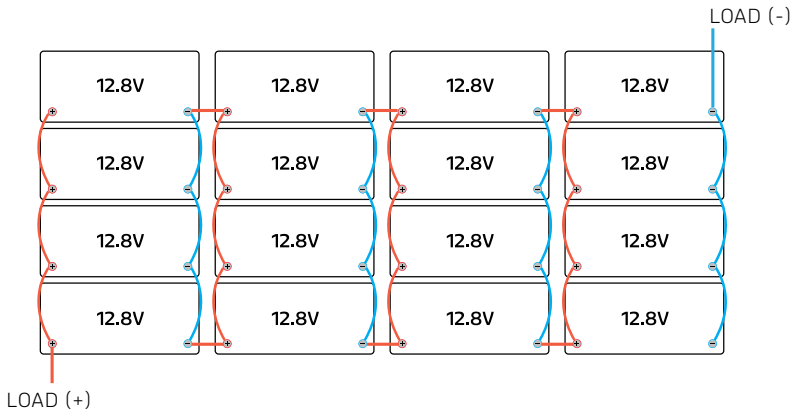

Taking a 12V 50Ah battery as an example, first, four 12V 50Ah batteries are connected in parallel, and then four 12V 200Ah batteries are connected in series, resulting in a battery pack with a total of 48V and 200Ah.

# —BMS FUNCTION

## **Over Charge Protection Voltage(>14.6V)**

If an individual cell voltage exceeds a prescribed threshold during charging, the BMS will stop the charging.

## **Over Discharge Protection Voltage(<9.2V)**

If an individual cell falls below the prescribed threshold during discharge the BMS will prevent further discharge when the battery voltage reaches over 21.6V, the battery will automatically reconnect after 15 seconds.

## **Charging High Temperature Protection**

The BMS will not allow a discharging current if the internal temperature of the battery has reached 149°F (65°C).

## **Discharging High Temperature Protection**

The BMS will not allow a discharging current if the internal temperature of the battery has reached 158°F (70°C).

## **Low Temperature Charging/Discharging**

The BMS will not allow a charging current under 32°F (0°C) but will continue to discharge down to -4°F (-20°C).

## **Over Current/Short Circuit Discharge Protection**

If the over current/short circuit protection is tripped, the BMS will shut the battery down and will remain disconnected until you remove the battery cables. While the battery cables are disconnected, we suggest taking the battery voltage with the use of a voltmeter. If it reads above 10.8V, reconnect the battery cables. If you are unsuccessful at obtaining a voltage reading above 10.8V, please contact our technical support team: [hello@super-empower.com](mailto:hello@super-empower.com).

# — APPLICATION EXAMPLES

## Wide Application

- RV
- Solar Energy Storage
- Industrial Battery
- Used to Replace 12V Lead-acid Batteries
- Home Energy Storage & Power Wall
- Nautical Applications
- Fishing, Boating Electronics
- Ice Fishing
- Recreational Vehicle
- Off-grid Life
- Deep Circulation Application



**BRIGHT MOBILE ENERGY**

**YOUR PROFESSIONAL  
MOBILE ENERGY SOLUTION PROVIDER**

For Details of SUPER EMPOWER Lithium Battery Please Visit

[www.super-empower.com](http://www.super-empower.com) 



## —FAQs

### **What should I do if the battery is 0V?**

Don't worry, if the battery is showing 0V this is potentially due to BMS protection. Please disconnect the battery cable from the load, test the battery voltage, if the voltage is more than 10.8V reconnect the battery cable. If the voltage is lower than 10.8V, please contact our technical team: [hello@super-empower.com](mailto:hello@super-empower.com)

### **Is it necessary to charge the battery out of the box?**

Yes, you need to fully charge the battery.

**NOTE:** Please also fully charge the battery if you want to connect the batteries in series or parallel.

### **How can I check the battery voltage?**

If you don't have a battery monitor, you can use a multimeter to monitor the voltage.

### **Can mount the battery in any position?**

You can mount our battery in any position. Please make sure to secure and protect the terminals when mounting.

### **FOR MORE FAQs, PLEASE VISIT OUR WEBSITE:**

[www.super-empower.com](http://www.super-empower.com)

# —WARRANTY AND RETURNS

## **Not covered by warranty:**

- Damage caused by insufficient or improper fastening.
- Improper installation, use, maintenance, or service.
- Loose battery terminal connections.
- Series connection of more than 4 batteries (51.2V above) or parallel connection of more than 4 batteries.
- Reverse polarity connection.
- Improper storage conditions defined in the battery user manual.
- Any short circuit caused by accidentally, intentionally, or unintentionally connecting the positive and negative terminals.
- Damage caused by impact, accidents, collisions, or drops.
- Insufficient/overcharging of the battery as defined in the battery user manual.
- Use in conjunction with other third-party products.
- High resistance caused by terminal corrosion, poor crimping, or undersized cables.
- Battery failure caused by electrical system malfunctions.
- Modification of the product without the explicit written consent of the manufacturer.
- Use of the battery for applications beyond its design and intended use, including repeated engine starting or consuming more amperes than the battery's rated continuous discharge to meet their respective specifications.
- Batteries left uncharged for more than 1 year (batteries should be charged regularly).

- Batteries used in commercial applications that cycle to a discharge depth of 80% or more within 24 hours.
- Force majeure, including fires, typhoons, floods, or earthquakes.
- Buyers are responsible for any damage caused by improper operation or misuse of our products and or failure to follow safety guidelines.

### **After-sales Service**

If you need any after-sales service for the product, please contact [hello@super-empower.com](mailto:hello@super-empower.com). We will provide you with the necessary assistance.

### **How to Store the Battery?**

We recommend bringing the Batteries to a 50% state of charge. Then, disconnect the battery from any loads by removing the negative cable from one battery. On average, the batteries lose <3% capacity per month at 77°F (25°C).

This is subject to increasing if stored in extreme environmental conditions.

### **Disposal and Recycling**

Ensure that the battery is properly disposed of in accordance with the laws and regulations in your area.

This product contains lithium-ion batteries and other recyclable materials.

We strongly encourage our customers to recycle used batteries.

*SUPER EMPOWER reserves the right to update all product data sheets at any time. Consult SUPER EMPOWER marketing specialists for publication updates at [hello@super-empower.com](mailto:hello@super-empower.com)*

*Copyright©2018–2025 SOLTECH LLC,  
All Rights Reserved.*



---

**"WE EMPOWER WATT MATTERS"**

**[www.super-empower.com](http://www.super-empower.com)**